

Technical What's New

AutoCAD®

Mechanical 2011



1	
2	
3	
4	1
5	2
6	2
7	1
8	1
9	1
10	1
11	2
12	1
13	2
14	1
15	1
16	6
17	12
18	13
19	13
20	1
21	6
22	8
23	4
24	2
25	1
26	1
27	1
28	1
29	1
30	2
31	2
12	2

Technical What's New

Welcome to AutoCAD® Mechanical 2011

Contents

Content Library	3
General Enhancements	3
<i>Localization</i>	3
<i>Improved International Standards</i>	3
<i>Update Content Selectively</i>	3
Part Publishing	3
<i>Import Data from Excel</i>	3
<i>Resize Content by Dragging</i>	3
<i>Select Geometry for New Views</i>	4
BOM, Balloons, and Parts Lists	4
BOM Migration Tool	4
Symbols	5
GOST Leader Enhancements	5
<i>Draw Standard Compliant Leaders</i>	5
<i>Attach and Align Leaders</i>	6
<i>Draw Surface Extension Lines</i>	6
Online Help Enhancements	6
<i>Align Leaders to Dimensions</i>	6
Power Dimensions	7
In-Place Editor	7
<i>Streamlined Design Environment</i>	7
<i>Create Dimensions</i>	7
<i>Edit Dimensions</i>	7
Proven Benefits	7
Stay Up to Date	7
Subscription	7
Product Updates	7
Autodesk Learning and Education	7
Licensing	8
Feedback	8
Conclusion	8

AutoCAD® Mechanical is AutoCAD® software for manufacturing. It contains all the functionality of AutoCAD plus a comprehensive set of features developed specifically to accelerate the mechanical design process. AutoCAD Mechanical automates many common tasks, such as generating mechanical components, dimensioning, and creating bills of materials. It supports international drafting standards and provides a library of over 700,000 standard parts. And, it enables drafters to quickly and easily detail and document digital prototypes created in Autodesk® Inventor® software.

The 2011 release includes numerous improvements, from usability features, BOMs, balloons, and parts lists to symbols and power dimension enhancements, including improved in-place editing functionality. AutoCAD Mechanical 2011 continues to offer mechanical engineers a competitive edge by saving them countless hours of effort.

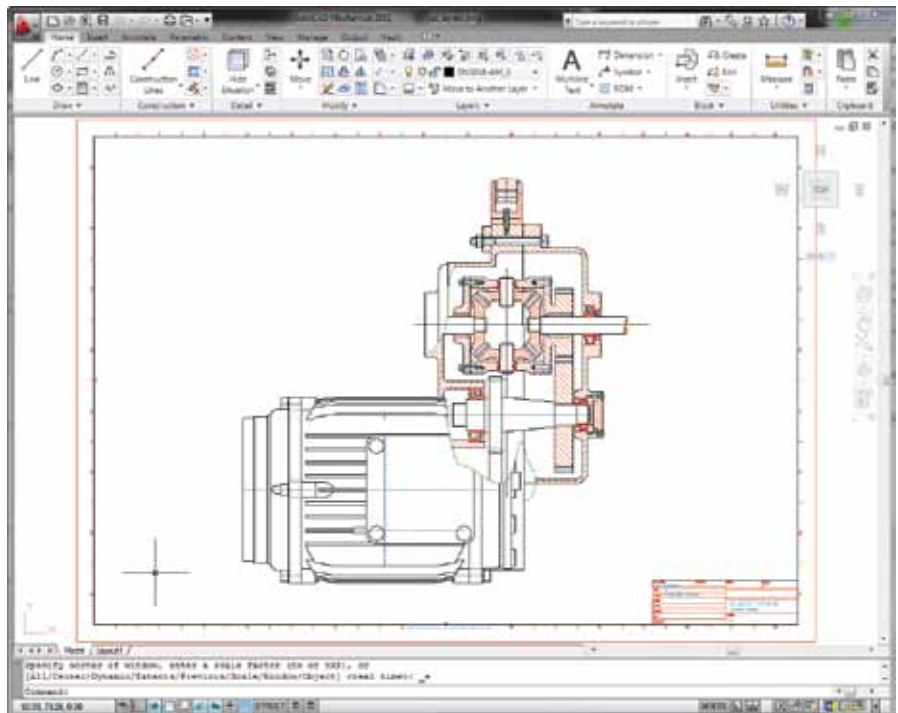

Technical What's New

Content Library

Create, manage, and standardize content more efficiently with enhancements to Content Library for standard features and custom parts.

General Enhancements

Localization

AutoCAD Mechanical 2011 software and documentation is now available in Brazilian Portuguese.

Improved International Standards

Support for Russian GOST standards is included in the software. Through a partnership with Softbank, Korean standards can be purchased as an add-in.

Update Content Selectively

If a content library was modified after you inserted a part/feature from it in a drawing, the parts/features in the drawing become out of date. Previously you had to double-click each part/feature in the drawing to update it. Now you can run the AMUPDATECONTENT command and select what parts/features to update.

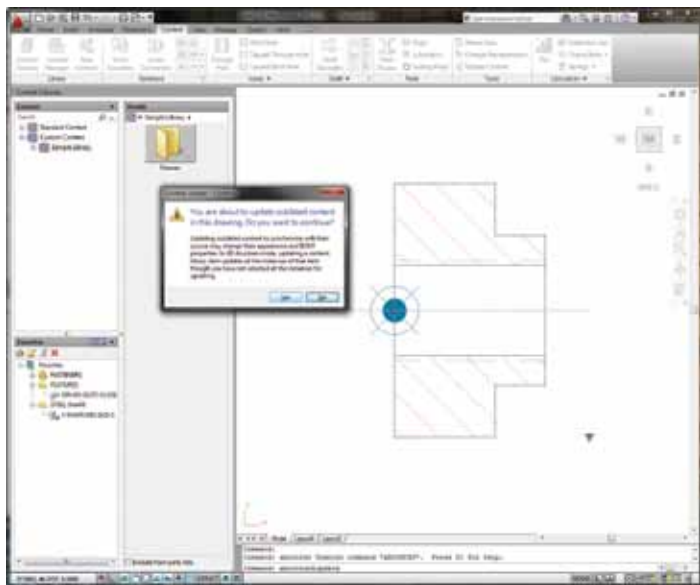

Part Publishing

Part Publishing enhancements make all features that previously applied only to standard parts now available for custom parts.

Import Data from Excel

You can now import XLS files directly to the Family Table.

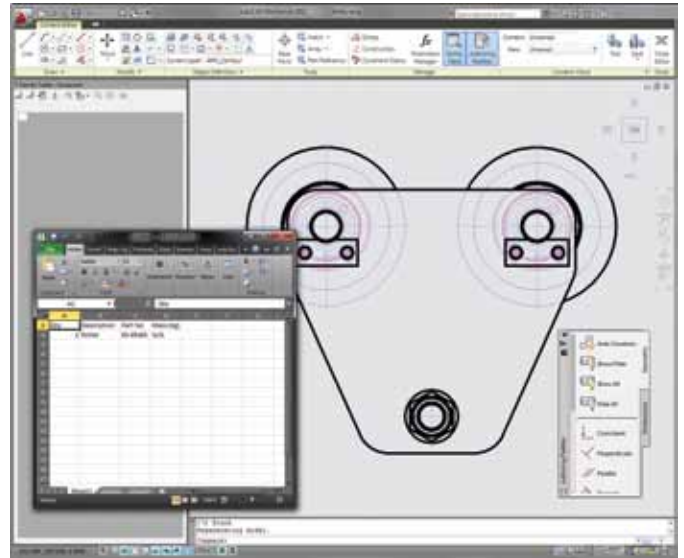

The first row of the Excel data is assumed to contain column names. Import replaces columns when names match columns that exist in the Family Table. It automatically creates new columns when no matching name is found. You can choose to append to or overwrite the existing data in the Family Table. You can also copy cells from an Excel Worksheet and paste them in a Family Table.

Resize Content by Dragging

When you dimensionally constrain a part/feature, you can specify that size selection must be performed at draw time. You specify that the dimension must have "drag grips" on its extension lines. Then AutoCAD Mechanical prompts you to drag to specify the size when you place the part/feature in a drawing.

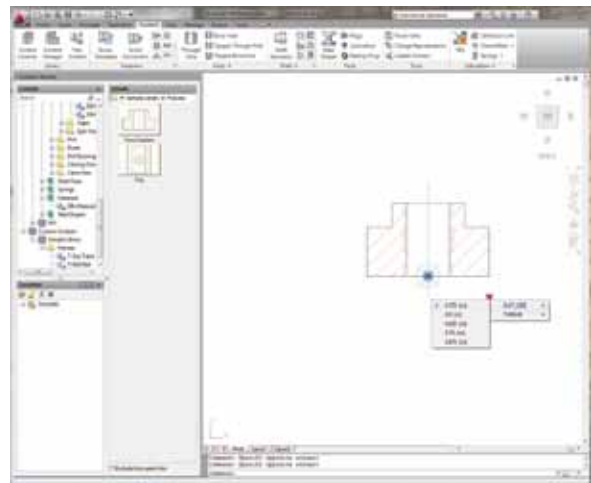

Technical What's New

Select Geometry for New Views

You can now select geometry for a new view directly from the New Content dialog box. Hence, you can now add views to a part/feature, while editing another view, using Quick View tools.

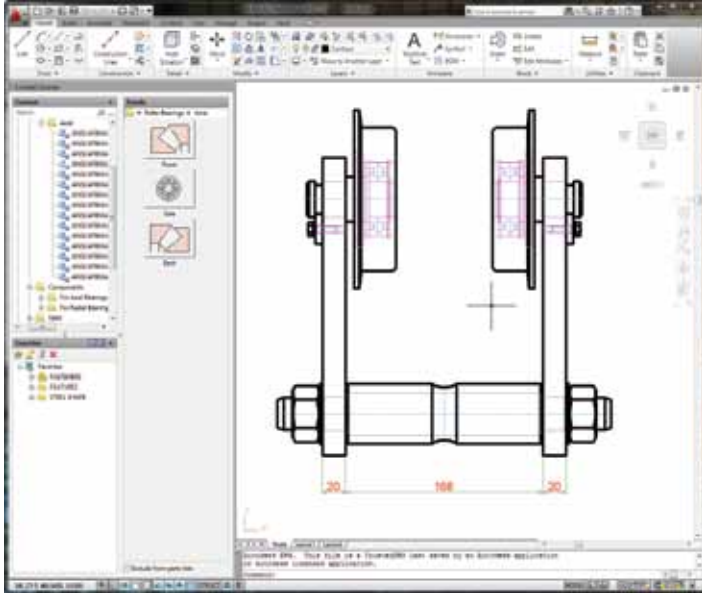

BOM, Balloons, and Parts Lists

Enhancements to AutoCAD Mechanical 2011 help you create accurate bills of materials (BOMs) and parts lists even faster.

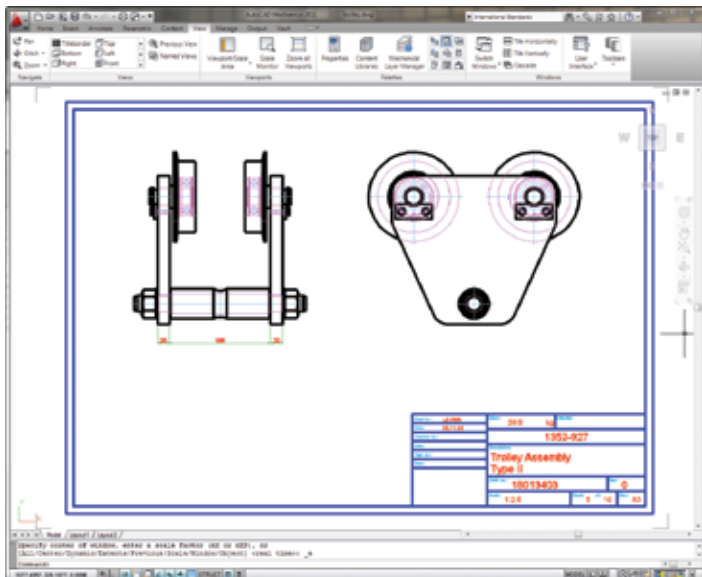

BOM Migration Tool

Generate BOMs for AutoCAD Mechanical drawings. If the parts list in an assembly drawing is a table that you typed manually, the BOM Migration Wizard can:

- Analyze the parts list
- Identify the part or subassembly drawing referred to in the parts list
- Generate a BOM for the assembly drawing as well as all other drawings referred to in the parts list

During migration, the wizard:

- Generates part references for each part and subassembly referred to in the parts list
- Attaches the BOM of each subassembly drawing to the corresponding part reference
- Attaches the assembly properties of each part drawing to the corresponding part reference
- Places the part references at the start point of balloon leaders

Finally the wizard:

- Replaces the manually typed parts list with a parts list that complies with the current drafting standard
- Replaces balloons with balloons that comply with the current drafting standard

Technical What's New

Additional enhancements to the BOM Migration tool add smart BOM functionality. Balloons will now be imported and AutoCAD Mechanical files are supported.

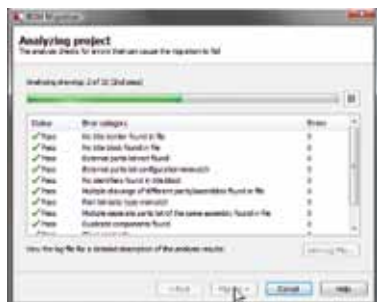
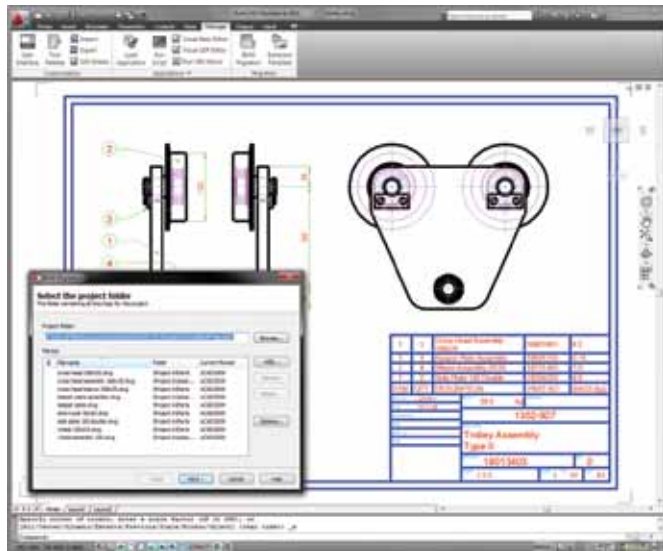

Symbols

AutoCAD Mechanical symbols help you produce consistent, accurate results—quickly and efficiently.

GOST Leader Enhancements

Draw Standard Compliant Leaders

To comply with GOST drafting standards, AutoCAD Mechanical now forces the first segment of the following symbols to be perpendicular to the attached object.

- Feature Control Frame Symbols (AMFCFRAME)
- Feature Identification Symbols (AMFEATID)
- Datum Identification Symbols



Regardless of where you move the pointer, the first segment continues to extend perpendicularly.

As per the standard, subsequent leader segments are now restricted to vertical or horizontal lines. Even when you grip edit a leader, the first leader segment remains perpendicular to the attached object. Subsequent leader segments continue to be horizontal or vertical.

AutoCAD Mechanical routes additional leaders, automatically adding leader segments to make it comply with the standard. When you add a leader, once you select the object to attach to, and move the pointer over the symbol, the preview updates to display the routed leader.

However, if you find this behavior too restricting, press SHIFT+Z and draw the leaders. This key toggles the degrees of freedom restriction applied by AutoCAD Mechanical.

Note: In feature control frames, the GOST standard is the only standard that does not require the reference line to remain horizontal.

Technical What's New

Attach and Align Leaders

All symbols now recognize the object you attach them to and will change behavior depending on the object type. When you attach a symbol to a circle, arc, or spline, the first leader segment extends perpendicularly from the selected object.

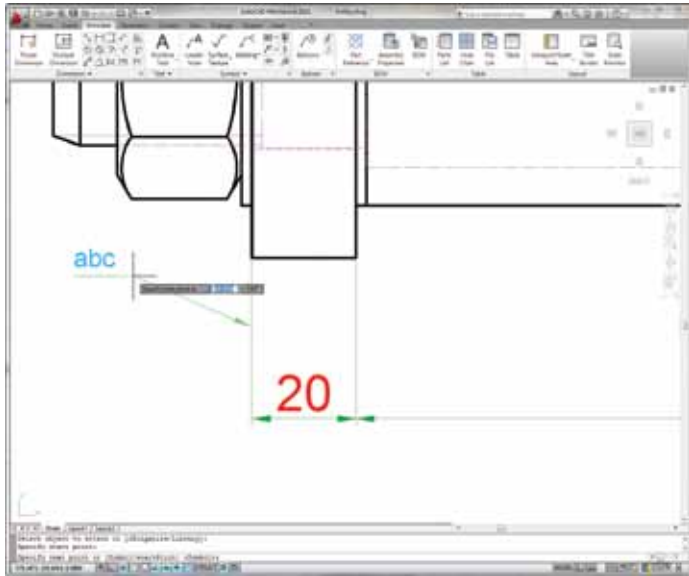

If required, you can override this behavior by pressing SHIFT+Z.

When you attach a symbol to a line, the first point you click automatically becomes the attach point. With some symbols, when Object Snap Tracking is turned on, you can track leaders along alignment paths. These assist you to easily create first leader segments that are perpendicular to the attached object. The symbols that display this behavior are:

- Leader Note (AMNOTE)
- Surface Texture (AMSURFSYM)
- Welding (AMWELDSYM)
- Edge (AMEDGESYM)
- Marking and Stamping (AMMARKSTAMP)
- Dead Joint (AMDEADJOINT)
- Taper and Slope (AMTAPERSYM)

Draw Surface Extension Lines

After you select the object to attach to, and move the pointer beyond the end of the line or arc, AutoCAD Mechanical draws extension lines.

When the distance between the cursor and the end of the arc is greater than the value set in the DIMEXO system variable, the surface extension line is displayed with an offset gap.

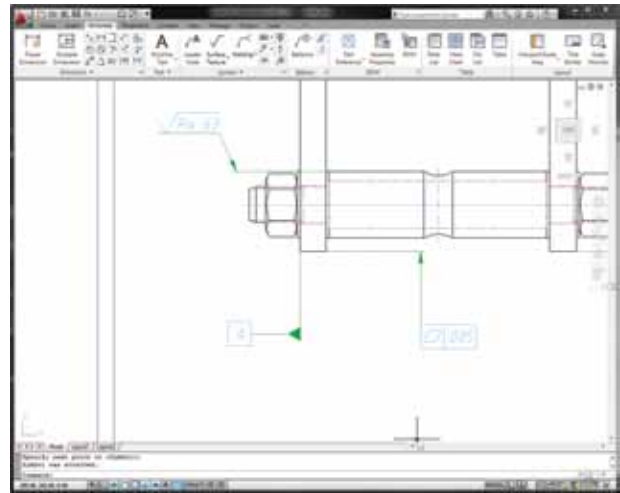

Online Help Enhancements

Align Leaders to Dimensions

The documentation has been expanded to provide instructions for complex aligning options. For example, to attach and align leaders to various dimension configurations.

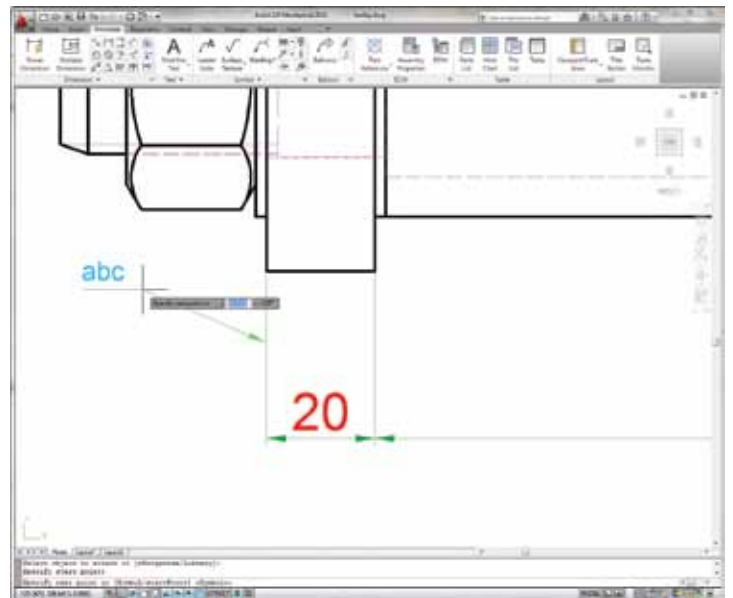

Technical What's New

Power Dimensions

AutoCAD Mechanical includes powerful and smart dimensioning tools.

In-Place Editor

Streamlined Design Environment

A streamlined tolerance and dimensioning UI has been incorporated into the ribbon, giving the canvas back to the user, so “what you see is what you get” when changes are made to dimensions.

Create Dimensions

The AMPOWERDIM family of commands has been enhanced to display an In-Place Editor and a contextual tab, instead of the Power Dimensioning dialog box. You can access all the options that were available in the Power Dimensioning dialog box, without having to switch tabs, as was the case previously.

If you prefer to use the Power Dimensioning dialog box, you can turn off the In-Place Editor by setting the AMPOWERDIMEDITOR system variable too.

Note: If the Ribbon is turned off, AutoCAD Mechanical displays the Power Dimensioning dialog box, irrespective of the value of the AMPOWERDIMEDITOR system variable.

Edit Dimensions

When you select a dimension for editing, the In-Place Editor is displayed. In the In-Place Editor, elements of the dimension text are grouped together to form chunks. You click a chunk to select it, and double-click to select related chunks. You can move, cut, copy, or delete the selection.

On the Power Dimensioning contextual tab, only the options applicable to that selection are available. Similarly the options available on right-click menus also depend on what you select.

To insert text, you click between chunks to insert and enter the text. You can also insert symbols from the symbol gallery. For example, if you want to insert text.

To insert a line break so that a part of the dimension text appears below the dimension line, place the cursor between two chunks and click on the ribbon.

Proven Benefits¹

In an independent productivity study¹ between basic AutoCAD and AutoCAD Mechanical, the results concluded that when using AutoCAD Mechanical:

- Drafting and annotation tasks are 55 percent faster
- Design and engineering tasks are 85 percent faster
- The number of commands used is reduced by 60 percent

For the complete study go to:

www.autodesk.com/autocadmechanical-productivity.

Stay Up to Date

Autodesk gives you more. Gain access to technical expertise, utilize training and support programs direct from Autodesk, stay up to date with the latest product releases, and give us your feedback. Not only does Autodesk want to help you use AutoCAD Mechanical more effectively but also make sure AutoCAD Mechanical is working effectively for you.

Subscription

Autodesk[®] Subscription gives you immediate access to software upgrades and exclusive access to service and support benefits designed to help you get the most out of your Autodesk software. Learn more at **www.autodesk.com/subscription**.

Product Updates

If you experience an issue with AutoCAD Mechanical 2011 that has already been solved in a service pack or hotfix, a dialog box appears when you submit the problem to Autodesk, enabling you to immediately install the new service pack or hotfix.

Autodesk Learning and Education

From instructor-led or self-paced classes to online training or education resources, Autodesk offers learning solutions to fit your needs. Get expert guidance at an Autodesk Authorized Training Center (ATC[®]) site, access learning tools online or at your local bookstore, and validate your experience with Autodesk certifications. Learn more at **www.autodesk.com/learning**.

Technical What's New

Licensing

Cascading network licensing supports customers who need to deploy multiple Autodesk products. AutoCAD Mechanical 2011 licenses can easily be combined with licenses for Autodesk Inventor. As AutoCAD Mechanical licenses are used, the network first chooses the stand-alone AutoCAD Mechanical licenses, then the Autodesk Mechanical Desktop licenses, and finally the applicable Inventor licenses.

Feedback

AutoCAD Mechanical customers can provide feedback to the AutoCAD Mechanical development team through several different avenues. For example:

- Provide tips or join newsgroups at www.autodesk.com/autocadmechanical
- Keep up-to-date on what's happening in your industry, stay in touch with other industry professionals, and take advantage of a host of online resources at the Manufacturing Community Portal at mfgcommunity.autodesk.com
- Talk with your Autodesk Authorized Reseller and support staff

Your input is crucial to our success and we look forward to receiving your suggestions.

Conclusion

We thank you for your continued support of AutoCAD Mechanical and hope you feel we are listening to your needs. We added the new and enhanced functionality to AutoCAD Mechanical 2011 to help make you more productive, make your company more competitive, and return true value to your bottom line.

¹ Designed by Autodesk and commissioned to an independent consultant, this study explores 10 common design challenges and shows direct comparisons of the time and effort required to accomplish each specific task in AutoCAD and AutoCAD Mechanical software. Read the complete study at www.autodesk.com/autocadmechanical-productivity.